

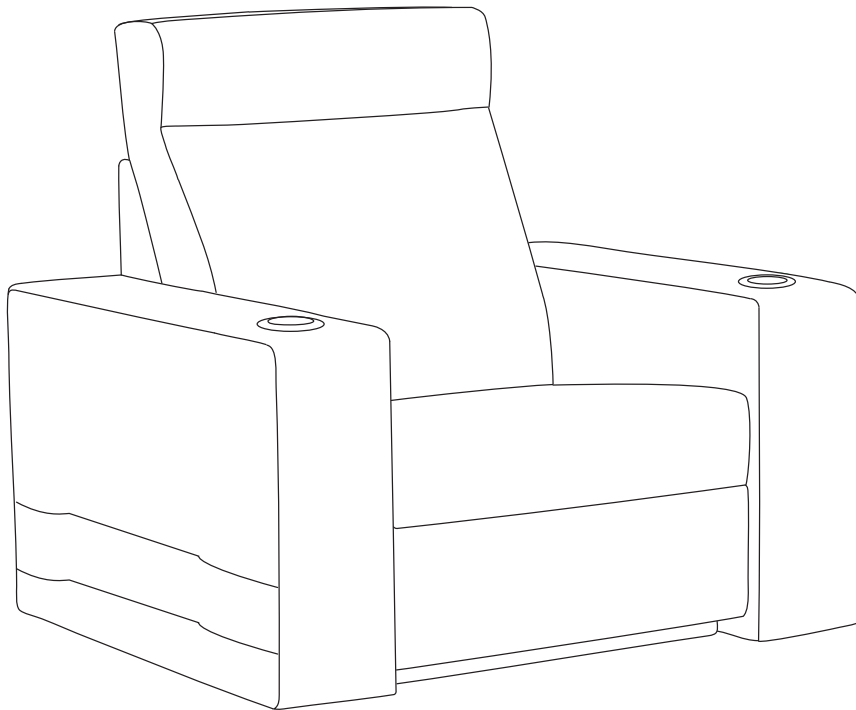

# OLIVIA

## Assembly Instructions



### Thank you for your purchase.

Unpack all content and check to ensure that all of the parts are in proper condition. To help protect the environment, use the appropriate recycling and discarding methods for the packaging items.

Read ALL assembly instructions before beginning. If you have any questions, please contact your installer or Salamander Designs at 800-535-5659.

### Tool Required:

Philips Screwdriver

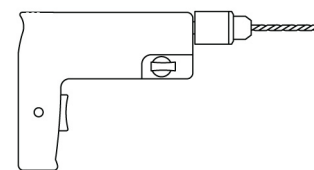

### PARTS - Supplied with Armless, Left and Right-End Chairs

①

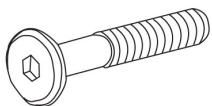

5/16 - 18 x 50 mm  
Connector Bolt  
Part# 012028

②

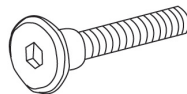

1/4 - 20 x 45 mm  
Connector Bolt  
Part# 002253

③

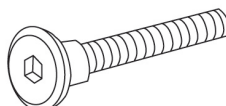

1/4 - 20 x 70 mm  
Connector Bolt  
Part# 003356

④



1/4 - 20  
Hex Nut  
Part# 005489

⑤

Spacers

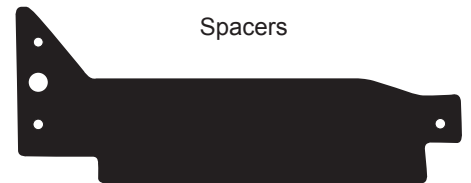

⑥

Hex Wrench  
Part# 005490

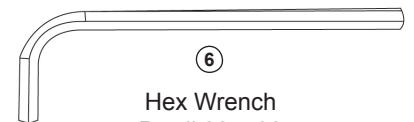

# 1 Attaching Back Rests

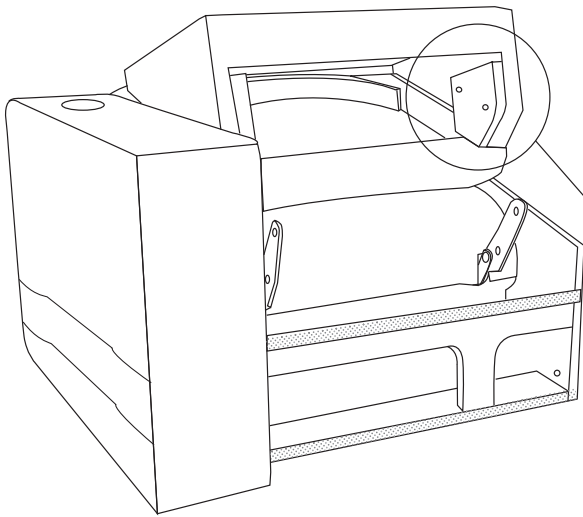

**A.** Remove four hand-tightened screws from the back rest frame.

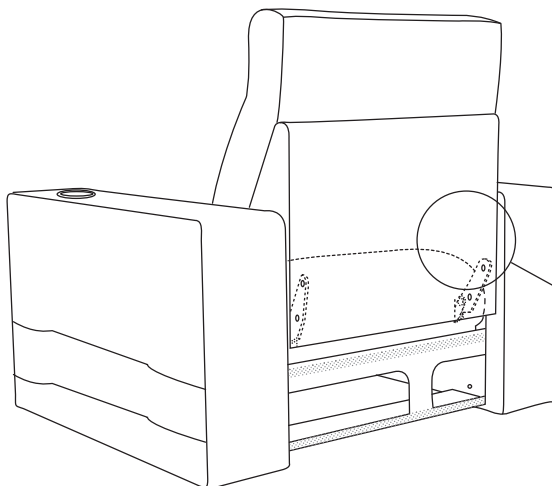
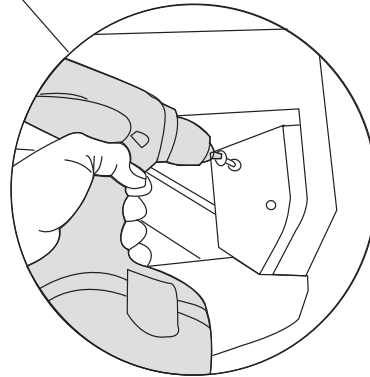

**B.** Remove lower back removable panel.

Align the backrest screw holes to the upper and lower holes in the chair mechanism tongues.

Install and tighten screws.

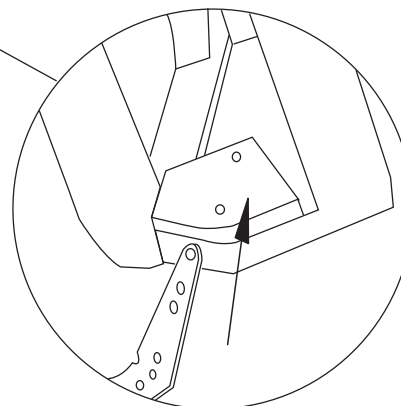

## 2 Tactile Transducer - Optional

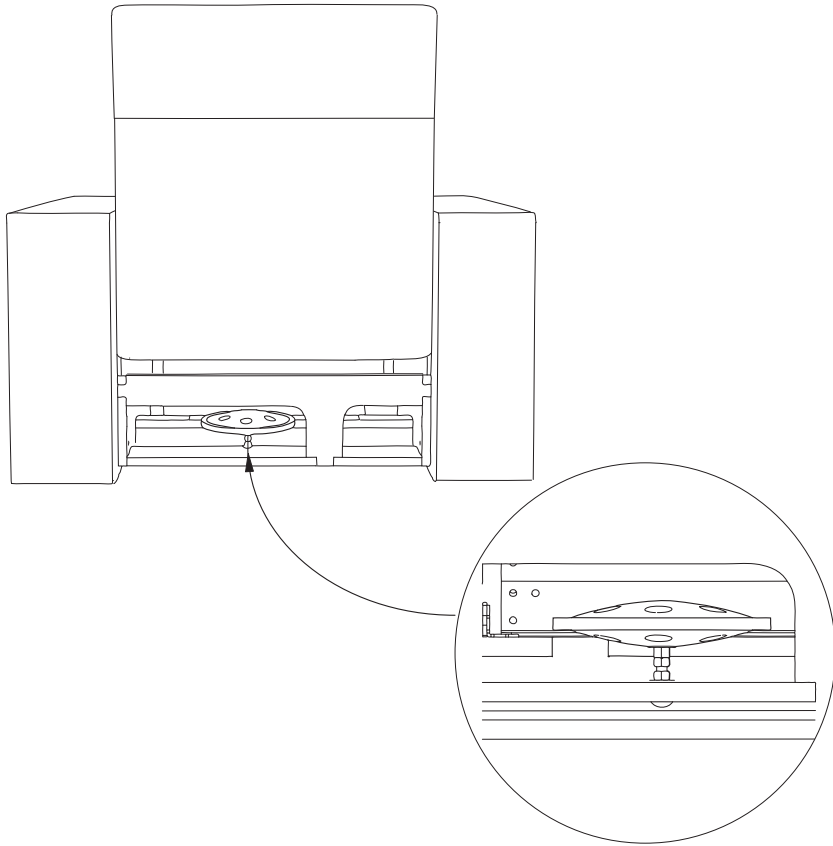

If you have purchased a Tactile Sound Transducer for your chair(s), install before connecting seats.

Remove lower back panel. Screw on jam nut included with transducer kit. Approximately 3/8" (10 mm) of threads should be exposed on bolt on chair frame. Screw transducer onto bolt to meet jam nut. Make sure transducer sits at least 1/8" (3 mm) above inner chair frame cross rail (adjust if necessary), tighten jam nut and transducer to lock in-place.

## 3 Power Seating - Optional

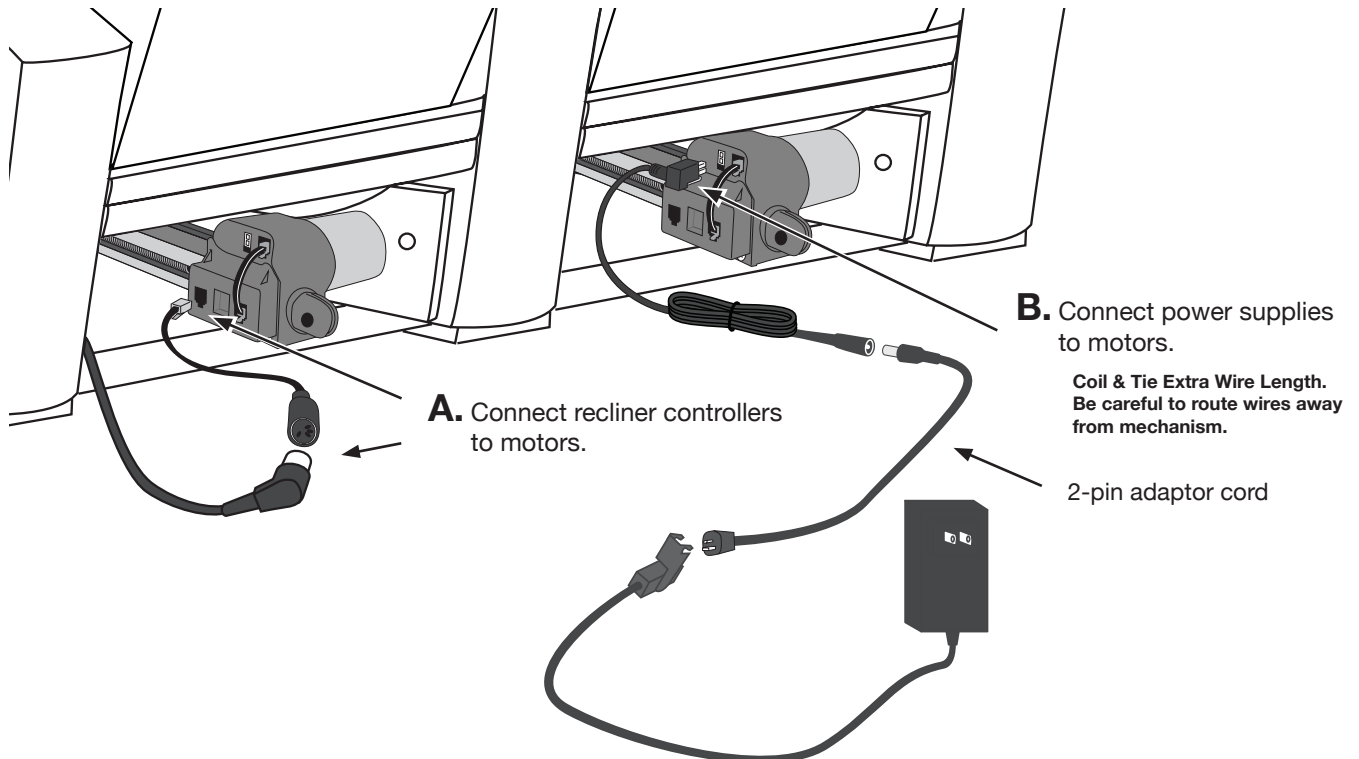

## 4 Connecting Seats to Arms (End Chair to Straight or Corner Section)

**A.** Align pieces in location, as they will be final assembled.

Align front and back bolt holes.

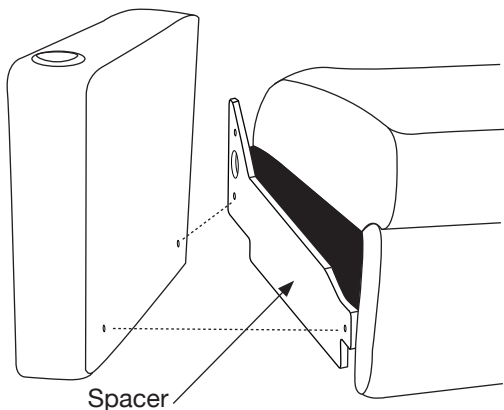

### Spacer info:

- Spacers are needed when connecting seats to arms. Each side of a seat that does not have an arm needs a spacer.
- Spacers match the shape of the chair bases and are attached along the side of the base.
- Spacers are unique to each model chair. Some are thicker than others. Some have upholstery applied.

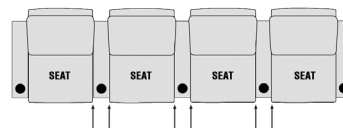

Example: In a configuration of 4 recliners 6 spacers are needed.

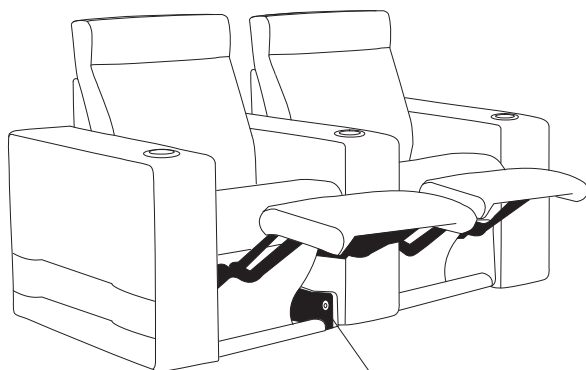

**B.** Extend foot rest to access front bolt holes and secure connection by inserting bolts (#1) through chair and into arm.

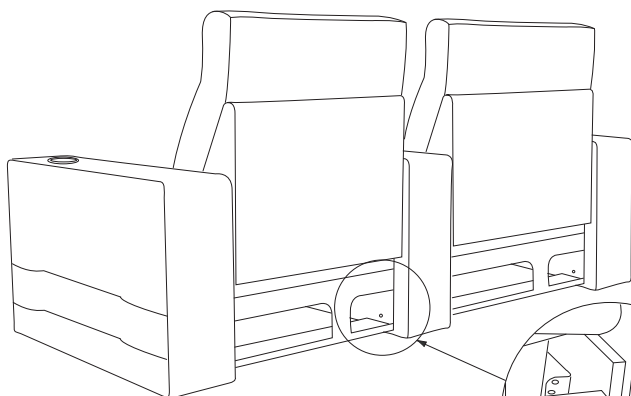
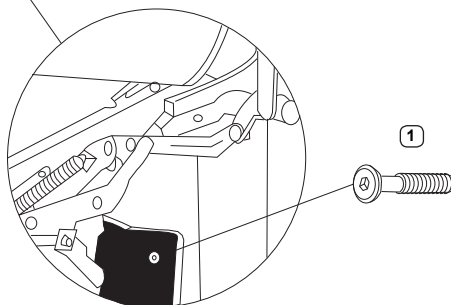

**C.** Remove lower back panels and locate the back bolt holes.

Secure connection by inserting bolt (#1) through chair and into arm.

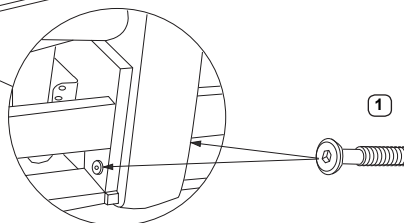

# 5

## Connecting Seat to Seat (Without Arms Between Seats) - Recliner to Recliner

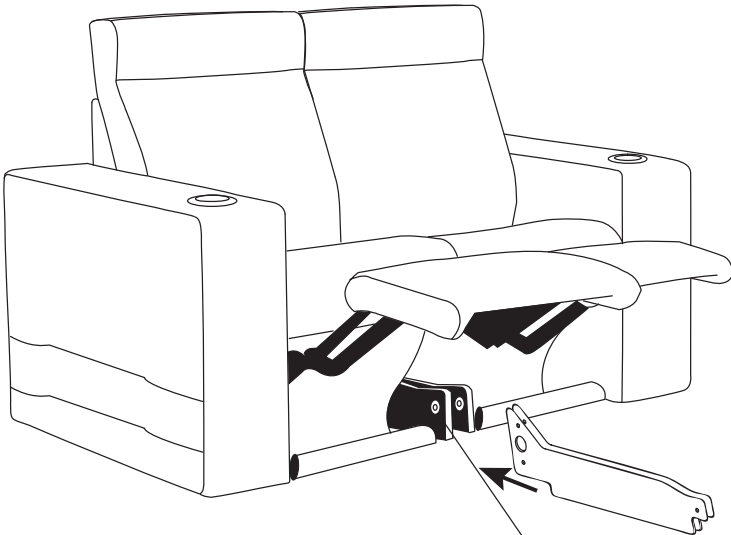

**A.** Extend foot rest to access front bolt holes.

Insert two 1/4" (6 mm) spacer panels between chairs (align bolt holes).

Secure connection by inserting bolt (#2) through chair frames.

Align front and back bolt holes.

Fasten with nut (#4).

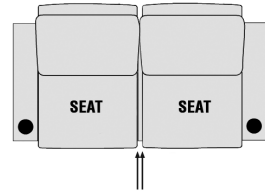

In this configuration of 2 spacers are needed between each seat.

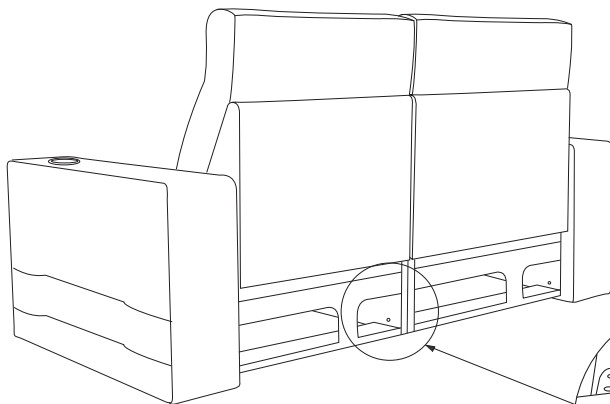
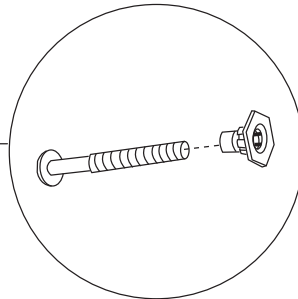
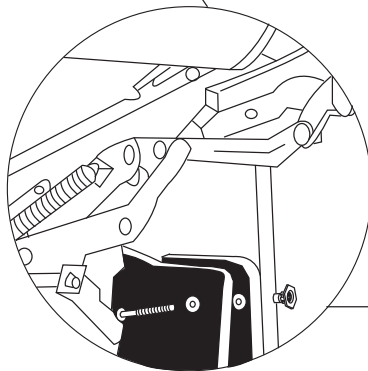

**B.** Remove lower back panel and locate the back bolt holes.

Secure connection by inserting bolt (#2) through chair frames.

Fasten with nut (#4).

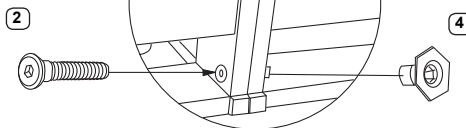

**6**

## Connecting Seat to Seat (Without Arms Between Seats) - Recliner to Non-Reclining Unit

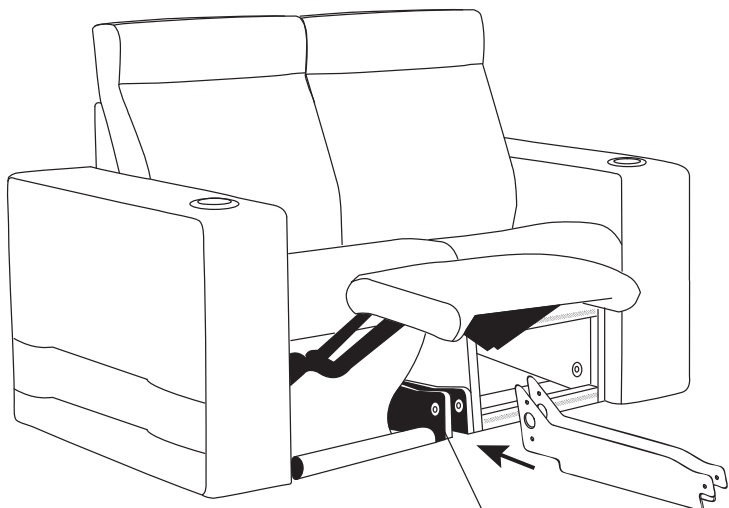

**A.** Extend foot rest on recliner, remove front panel on chair (pull outward to disengage hook & loop fasteners) to access front bolt holes.

Insert two 1/4" (6 mm) spacer panels between chairs (align bolt holes).

Secure connection by inserting bolt (#2) through chair frames.

Align front and back bolt holes.

Fasten with nut (#4).

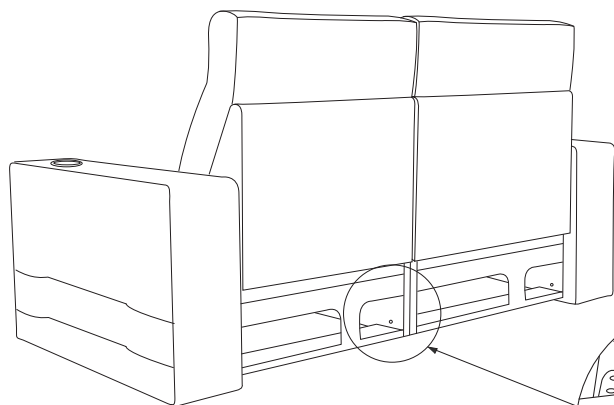
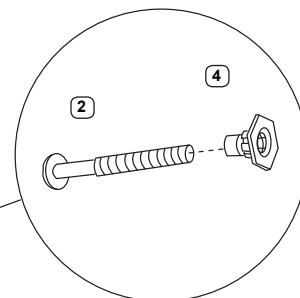
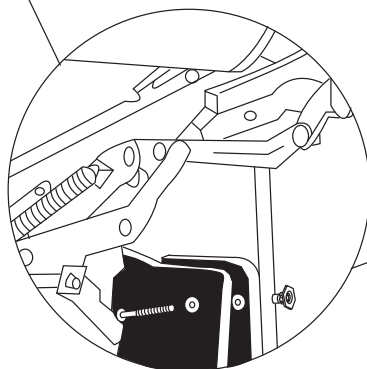

**B.** Remove lower back panel and locate the back bolt holes.

Secure connection by inserting bolt (#2) through chair frames.

Fasten with nut (#4).

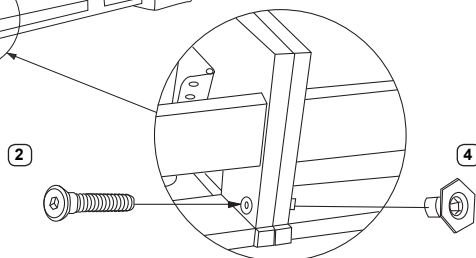

# 7 Connecting Seat to Seat (Without Arms Between Seats) - Recliner to Chaise

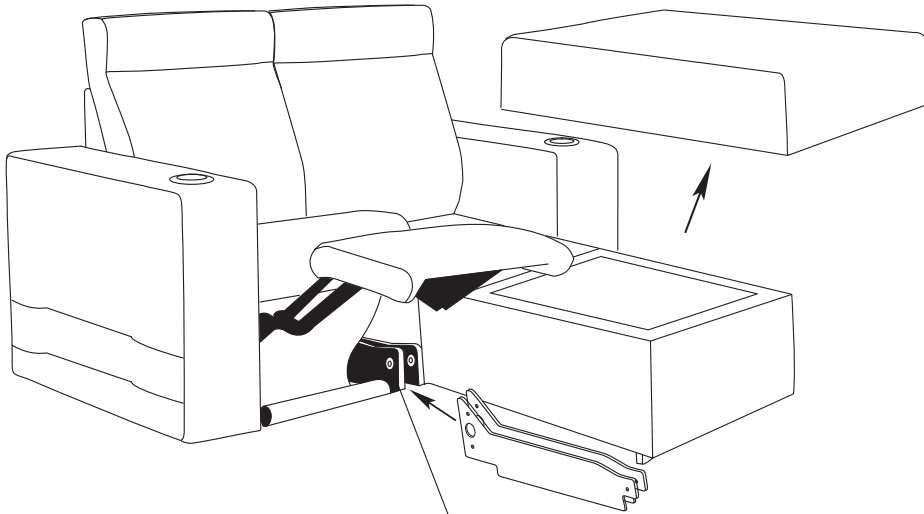

**A.** Extend foot rest on recliner, remove seat on chaise (lift seat up to disengage hook & loop fasteners) to access front bolt holes.

Insert two ¼" (6 mm) spacer panels between chair and chaise (align bolt holes).

Secure connection by inserting bolt (#2) through chair frames.

Align front and back bolt holes.

Fasten with nut (#4).

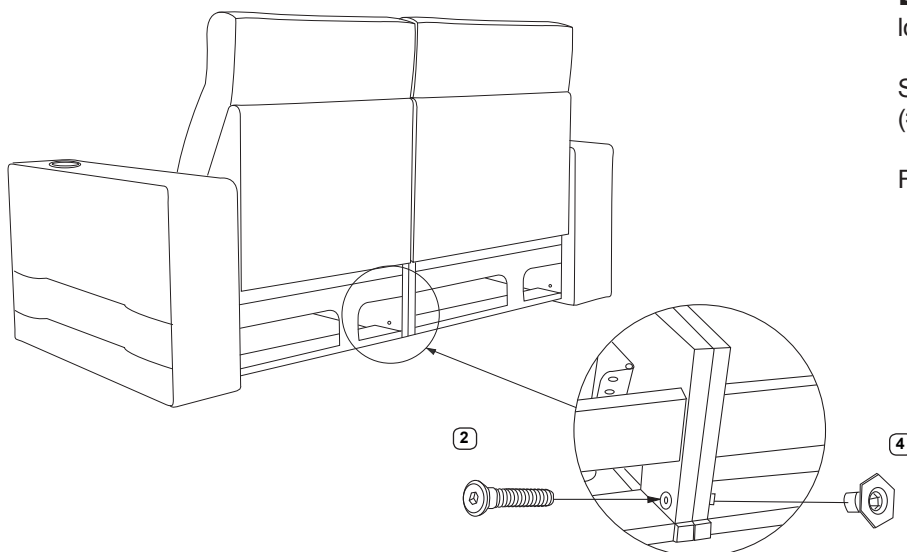
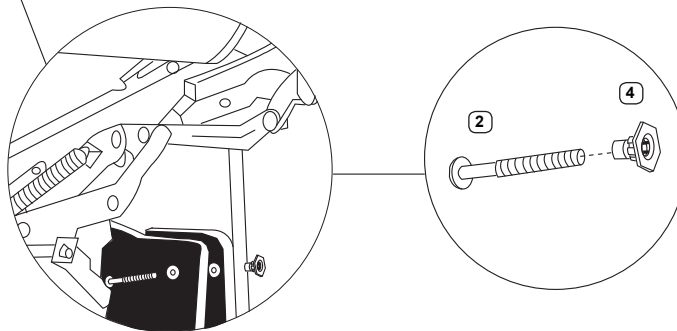

**B.** Remove lower back panel and locate the back bolt holes.

Secure connection by inserting bolt (#2) through chair frames.

Fasten with nut (#4).

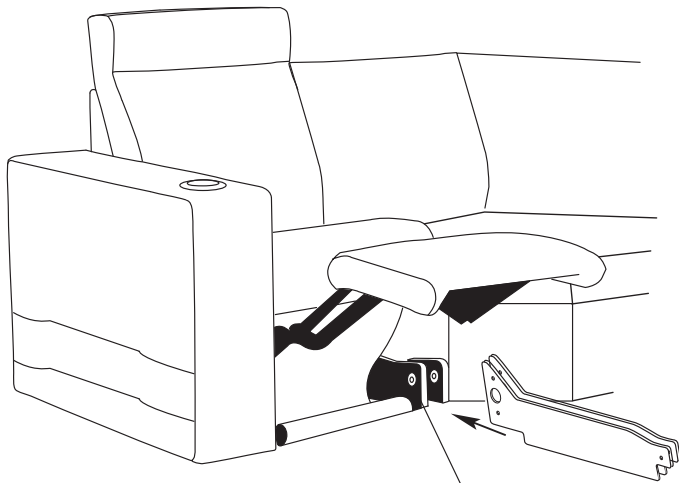
**8****Connecting Seat to Seat (Without Arms Between Seats)  
- Recliner to Corner Seat**

**A.** Extend foot rest on recliner to access front bolt holes.

Insert two 1/4" (6 mm) spacer panels between chair and corner.

Align front and back holes.

Secure connection by inserting bolt (#2) through chair frames into pre-installed T-nut in corner.

Tighten.

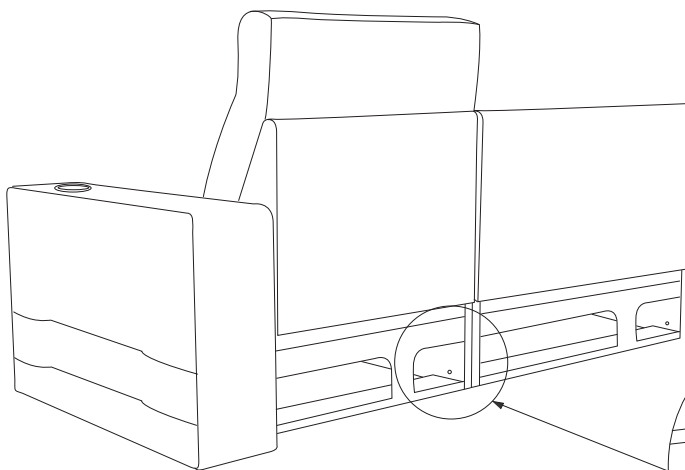
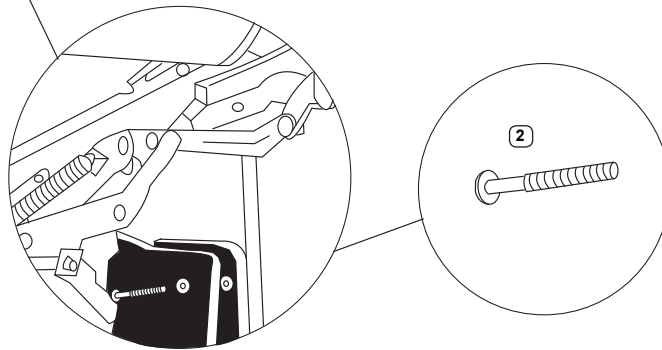

**B.** Remove lower back panel on recliner and locate the back bolt holes.

Secure connection by inserting bolt (#3) through chair frames into pre-installed T-nut in corner.

Tighten.

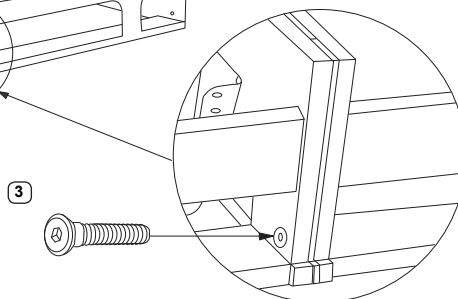



## 9 Connecting Seat to Seat (Without Arms Between Seats) - Non-Reclining Unit to Non-Reclining Unit

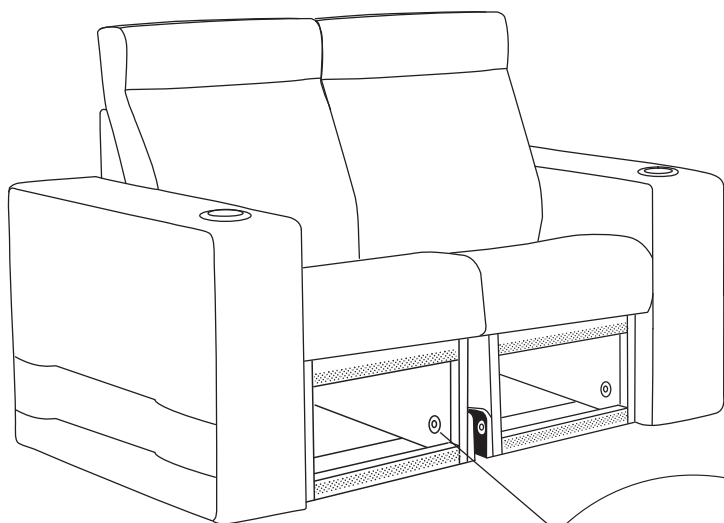

**A.** Remove front panel on chair or seat on chaise to access front bolt holes.

Secure connection by inserting bolt (#3) through chair frames. (DO NOT use spacer panel supplied with recliner).

Align front and back bolt holes.

Fasten with nut (#4).

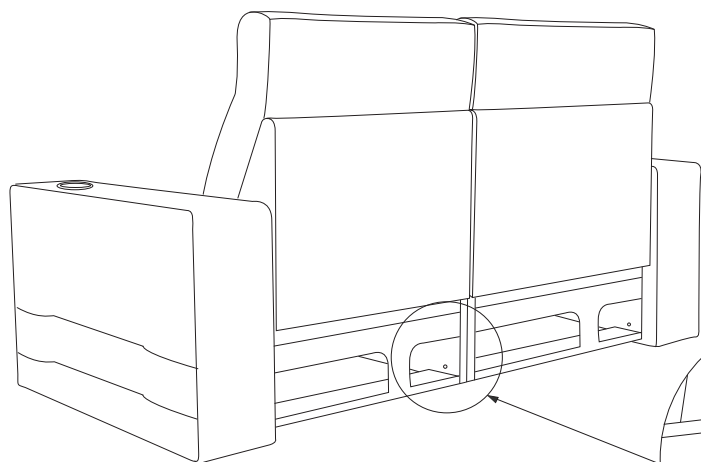
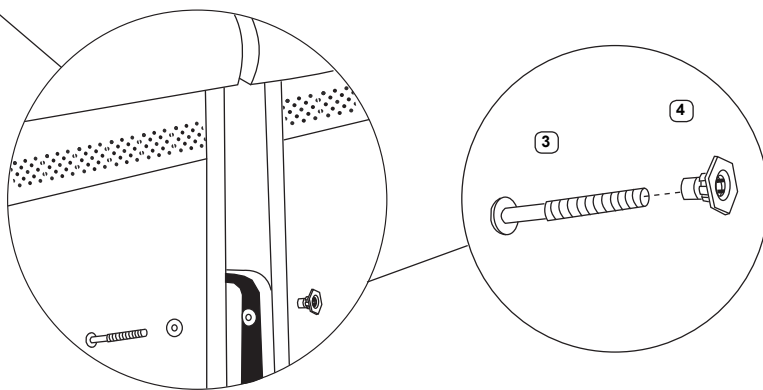

**B.** Remove lower back panel on recliner and locate the back bolt holes.

Secure connection by inserting bolt (#3) through chair frames.

Secure connection by inserting bolt through chair frames into pre-installed T-nut in corner.

Tighten.

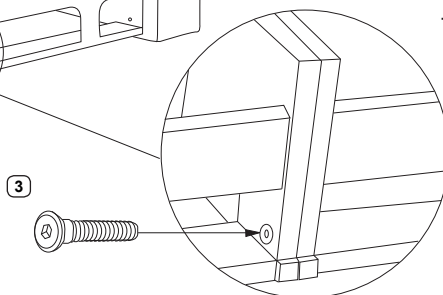

## **Salamander Seating Limited Lifetime Warranty**

Salamander Designs Ltd. (Salamander) provides the following Limited Lifetime Warranty. The Limited Warranty herein described for the specific products listed below shall be in lieu of any other warranty, expressed or implied, including but not limited to any implied warranty of merchantability or fitness for a particular use. The Limited Warranty does not cover damages incurred in shipment, failures caused by other products not supplied by Salamander, or failures due to accident, misuse, abuse or alteration of the product. No warranty is provided to business, commercial, rental, institutional and other non-residential users or seating purchased from retail showroom displays. Salamander's sole liability and the purchaser's exclusive remedy shall be for the repair, or at Salamander's option, for the replacement of the defective part as provided herein. Notwithstanding the above, if replacement parts for defective materials are not available, Salamander reserves the right to make reasonable compensation in lieu of repair or replacement. Liability for incidental or consequential damages under the warranty is excluded. Some states do not allow limitation of incidental or consequential damages. Therefore, the above limitation may not apply in certain instances. Defective product must be given Return Authorization by Salamander and is to be returned to the factory, in proper packaging. Any damage incurred in a shipment not in proper packing shall be the responsibility of the purchaser. This warranty gives you specific rights and you may also have other rights that could vary in your area.

### **Powered Mechanism**

Salamander provides a one (1) year Limited Warranty on our powered reclining mechanism. This warranty covers the repair or replacement of the powered reclining mechanism against manufacturing defects when used in a normal manner.

### **Cushioning**

Salamander provides a two (2) year Limited Warranty against tearing or collapsing due to defects in material or workmanship. Please note that all foams and composites naturally soften with use. This softening does not constitute a defect under the warranty.

### **Fabric/Leather**

The Limited Warranty on the fabric covers defects in material or workmanship for one (1) year that result in seam failure, fabric separation, nap loss, leather splitting, natural scars opening, premature fading or pilling under normal conditions. The fabric Limited Warranty does not apply where there is evidence of excessive soiling, improper cleaning, abuse, or where the fabric has had a chemical treatment applied by the retail dealer or the consumer.

### **Warranty Procedure**

Claims should be made through the dealer from which the product was purchased. The dealer will contact Salamander Designs Ltd. (Salamander) for warranty service. An original sales order number/purchase order number will be required for warranty protection. Salamander's liability under this warranty is limited to repairing or replacing at Salamander's option any part(s) of the product found to be defective in material or workmanship within the applicable warranty period. Salamander in its sole discretion will determine the cause and nature of any defect, the necessity and manner of repair or replacement, and all other matters pertaining to the condition of the product.

### **Labor and Shipping Charges**

Should you be entitled to receive a repair or replacement under this warranty, Salamander will pay the cost of labor, handling and shipping to the consumer for two (2) years from the date of purchase by the original consumer. After that date, the purchaser will be responsible for these costs.

## **Leather Care**

Leather is a natural product and variations in color can occur, along with minor flaws such as scars. We therefore recommend that you look after your chair by not exposing it to direct sunlight or placing it too close to a heat source, such as a radiator, which will cause the leather to dry.

To remove any dust and dirt we recommend vacuuming with a soft brush. To remove simple stains (water soluble) please use a soft cloth or sponge with a little water.



**SALAMANDER  
DESIGNS**

Furniture Shaped By Your Needs ®

phone: 800-535-5659

[www.SalamanderDesigns.com](http://www.SalamanderDesigns.com)